

LINEAR THERMOMETER

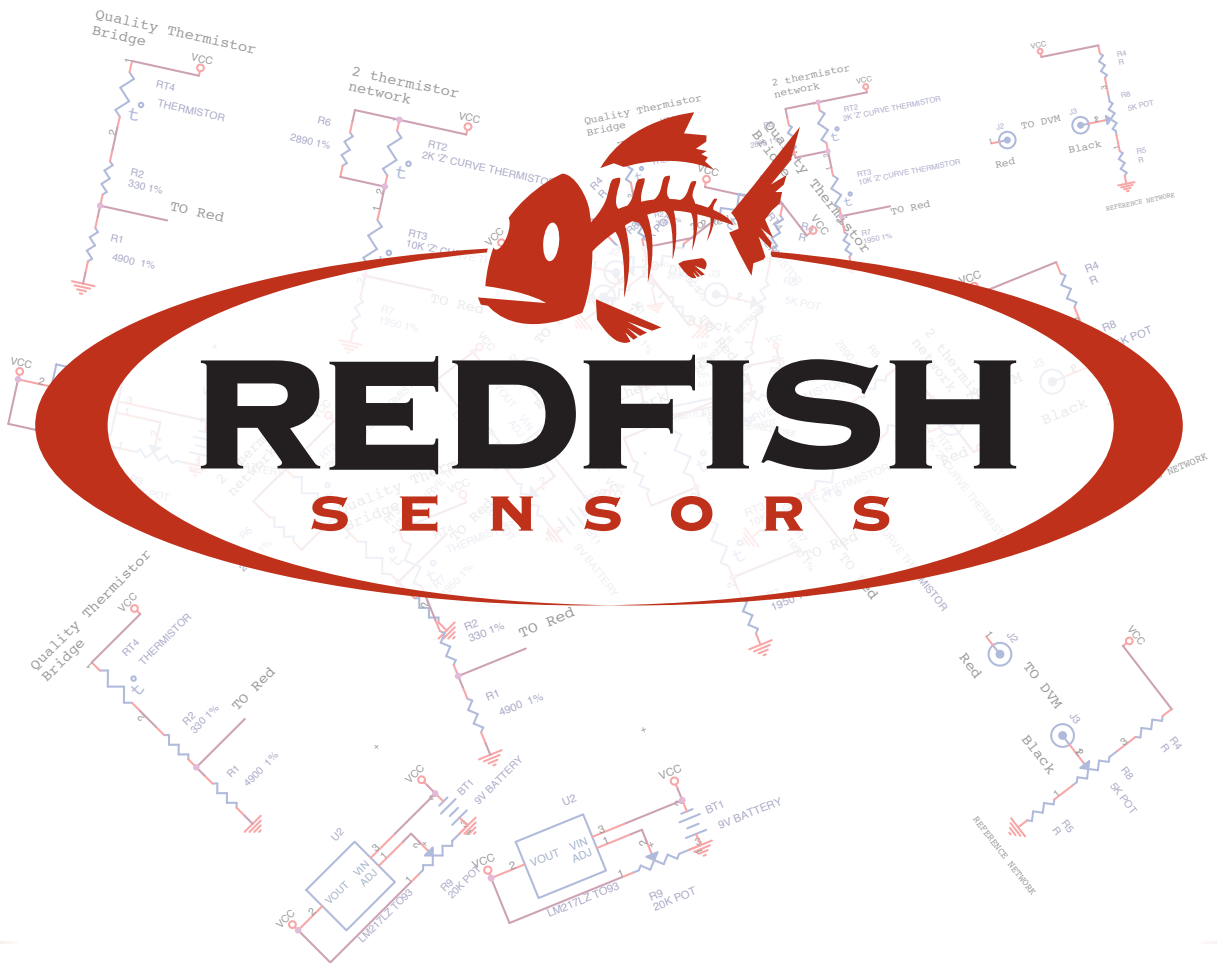



How it works!

Temperature Controller

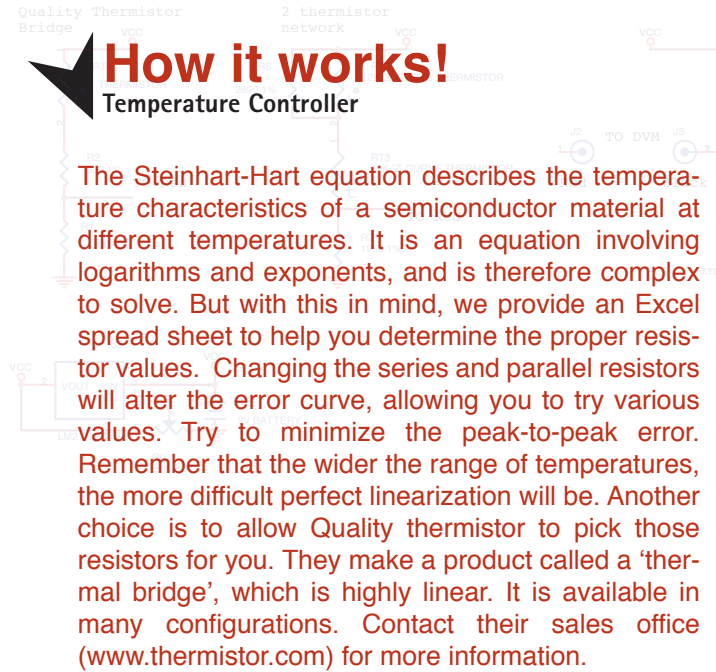

The Steinhart-Hart equation describes the temperature characteristics of a semiconductor material at different temperatures. It is an equation involving logarithms and exponents, and is therefore complex to solve. But with this in mind, we provide an Excel spread sheet to help you determine the proper resistor values. Changing the series and parallel resistors will alter the error curve, allowing you to try various values. Try to minimize the peak-to-peak error. Remember that the wider the range of temperatures, the more difficult perfect linearization will be. Another choice is to allow Quality thermistor to pick those resistors for you. They make a product called a 'thermal bridge', which is highly linear. It is available in many configurations. Contact their sales office (www.thermistor.com) for more information.

The resistor/thermistor network forms one-half of a bridge, with R5 and R4 making up the other half. The R5/R4 ratio determines the zero point, set by the potentiometer, and the reference voltage determines the slope (millivolts per degree) of the response. The design, with resistors selected, makes a thermometer with a range of 70 degrees Centigrade and a linearity error of +/- 3° C. As a general rule, if you pick a series resistor equal to the thermistor in value at the center of the temperature range you want to measure, you will closely approximate a linear curve.

Another choice is to build a two thermistor network. In this way, one thermistor's curve complements the other, offering a wider range, higher linearity temperature probe. With the values shown, the probe offers -5 to +100 degree range, with +/- .75 degree non-linearity.

Calibration methods can include an ice bath and an oral thermometer. An ice bath should include a pint or quart jar, with crushed and cube ice. The jar should be wrapped tightly on the sides and bottom with an insulating material such as newspaper or blanket, and well stirred. The temperature will be very close to 0 degrees C, 32 F. An oral thermometer using the same jar and stirred warm water will register 98.6 degrees Fahrenheit within a few tenths of a degree. Add warm water slowly, and be sure not to exceed about 105 degrees, or the thermometer will break! This will allow calibration at low and high temperatures. Of course, there are calibration thermometers for almost any temperature available commercially. Use the potentiometer in the reference resistor network to set zero degrees (intercept), and potentiometer R9 to adjust the high temperature point (span).

We have chosen to use any commercial digital voltmeter as the read-out device. The 199.9 millivolt range will give a resolution of .1 degrees. A typical choice would be a Radio Shack 15 range digital multimeter model #22-810, catalog number 22-810. One percent resistors are available through Digi-key, Allied Radio, and others. In order to get exact values, you may need to use several resistors in series (add up the values). Small boxes for enclosure of parts and battery are available from DigiKey, typically the A-219V. Small parts assembly boards are from Radio Shack #276-150 catalog #276-150

PARTS LIST (SINGLE)

REFERENCE	PART	VENDOR	PART NUMBER
RT4	10K 'Z' curve thermistor	Quality Thermistor	
R2	330 ohms 1%	DigiKey	P330CACT -ND
R1	4900 ohms 1%	DigiKey	P4.70KCACT -ND
R5	4900 ohms 1%	DigiKey	P4.70KCACT -ND
R4	32660 ohms 1%	DigiKey	P30.0KCACT -ND

PARTS LIST (DUAL)

REFERENCE	PART	VENDOR	PART NUMBER
RT2	2K 'Z' curve thermistor	Quality Thermistor	
RT3	10K 'Z' curve thermistor	Quality Thermistor	
R5	1950 1%	DigiKey	P2.00KCACT -ND
R6	2890 1%	DigiKey	P3.00KCACT -ND
R7	1950 1%	DigiKey	P2.00KCACT -ND
R4	9187 1%	DigiKey	P9.10KCACT -ND

PARTS LIST FOR EITHER PROJECT

REFERENCE	PART	VENDOR	PART NUMBER
Digital Voltmeter		Radio Shack	#22-810
Case		DigiKey	A-219V
PCB Prototype Board		Radio Shack	#276-150
R9	1K ten turn potentiometer	DigiKey	3005-102-ND
Voltage Reference	LM217ZL, TO92	DigiKey	497-1573-1-ND
Red connector		DigiKey	J151-ND
Black Connector		DigiKey	J152-ND
9V Battery		anywhere	

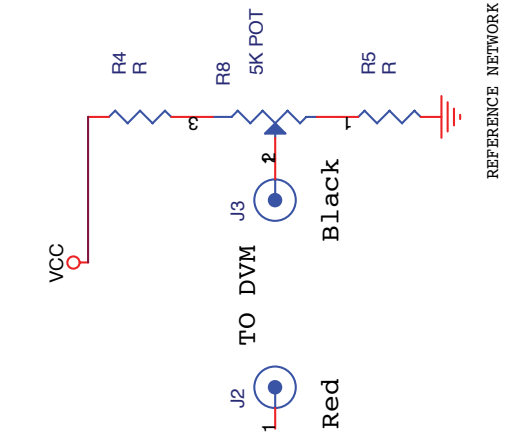
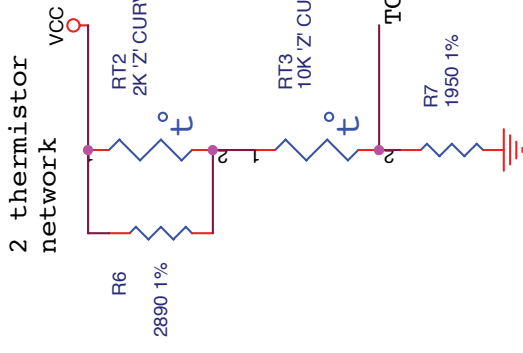
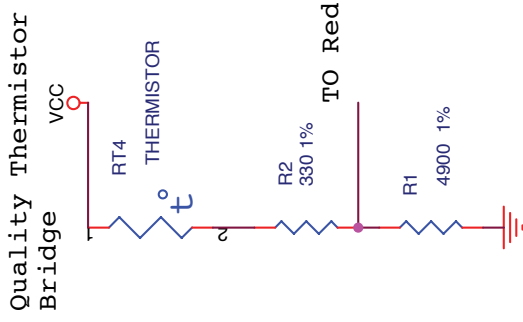

Notes;

Quality Thermistor Bridge

Company supplies thermistor and resistor, optimized for best linearity. R5 equal to R1, and R4 equal to thermistor at 0 degrees. The reference voltage should be 1.25 volts. Use R9 to adjust span.

2 thermistor network

2 thermistor network offers greater linearity over a wider range. R7 equal to R3, and R4 equals thermistor network at 0 degrees. The reference voltage should be 1.75 volts. Use R9 to adjust span.

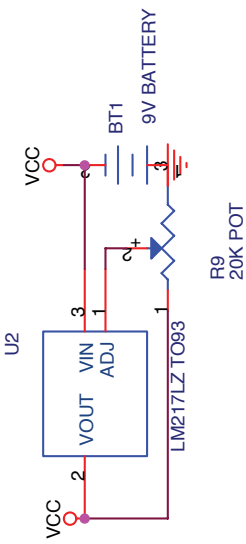

See spread sheets for further details

Title		LINEAR THERMOMETER	
Size	A	Document Number	<Doc>
Date:	Wednesday, October 31, 2007	Sheet	1 of 1
Rev	A		